

# The effect of surfactant solutions on the growth rate of environmental stress cracking of low-density polyethylene

YOSHIHITO OHDE, HIROSHI OKAMOTO

*Department of Engineering Sciences, Nagoya Institute of Technology, Gokiso-machi, Shouwa-ku, Nagoya, 466, Japan*

The growth rate of environmental stress cracking (ESC) of low-density polyethylene (PE) specimens bent and immersed in surfactant solutions has been measured. In the temperature range 25 to 60°C, the values of the growth rate are almost independent of the amount of deformation varying in a narrow range but dependent on it below 25°C. They are changed over a few hundredfold by the changes of temperature and of surfactant solutions. The growth of ESC of PE is assumed to be a stress-assisted thermal activation process. In the temperature range 25 to 60°C, the values of activation enthalpy obtained depend on the surfactants used, but are almost independent of their concentrations. The growth rate was measured under hydrostatic pressure up to  $2.25 \times 10^7 \text{ N m}^{-2}$  (220 atm). A few of the values of the dilation activation volume were evaluated. The nature of the mixture-like (surfactant and PE) region developed on PE surfaces at crack tips and the increase in the mobility of PE segments there seem to be essential to ESC of PE.

## 1. Introduction

In the presence of certain liquids, a polyethylene (PE) specimen subject to a complex stress sometimes fractures in a brittle manner after an interval of time. The stress referred to is insufficient to fracture the material in the absence of the liquids. This is known as environmental stress cracking (ESC). Examples of ESC active liquids are surfactant aqueous solutions, alcohols, and many other liquids. Similar cracking phenomena are observed in other polymers [1].

Many technological aspects of ESC of PE have been studied [1, 2]. Most studies concern "time to fracture" which is the time interval from the onset of loading to the fracture appropriately defined. Because ESC is a delayed fracture, the rate of crack creation and the rate of crack growth should be distinguished. The notion of "time of fracture" cannot bear strict examination in this sense.

Williams *et al.* [3] studied the growth rate of ESC (and environmental stress crazing) of polymers including polymethylmethacrylate and high-density PE. By an analysis based on fracture mechanics, they found three regions, I, II, and III, in

ESC of polymers as Wiederhorn found in inorganic glass. In region I, the growth of ESC is considered to be relaxation-controlled and in region II, the growth is controlled by liquid flow into the crack tip region. In region III, cracks grow as if in inert environments. Recently, in a study of ESC of high-density PE, Saito tried to relate the crack-growth rate with the overall strain rate under a creep condition through a geometrical approximation [4].

In ESC of amorphous glassy polymers, active liquids are generally solvents of small molecules and cracking is considered to be induced by plasticization [5]. Above the glass temperature, however, Andrews and Bevan [6] pointed out that surface energy reduction is a primary factor.

A few studies have been made to clarify the interaction between PE and surfactant molecules which causes ESC. Surfactant molecules will not swell the unstressed PE [1, 7]. Brown [8], however, indicated that the stress in PE will increase the solubility [7, 9] and proposed the PE ESC is caused by the stress-induced plasticization effect. On the other hand, Haward and Owen [10] suggested that

surface energy reduction is responsible for PE ESC from their study of failure of a cylindrical void model simulating crazed polymer structure.

A sophisticated way to develop a single, linear, and steady crack in a low-density PE specimen under a constant bending deformation was found in our laboratory [11]. Since then, the growth rate of ESC of PE has been studied. Surfactant aqueous solutions and *n*-propanol have been exclusively used as ESC active liquids. The effect of the liquids on the growth rate is reported here. The study of the crack creation rate is postponed as a future problem. In this paper, the rate-determining process of the crack growth is reasonably assumed to be a stress-assisted thermal activation process. The values of the growth rate in our experiment were so low that the flow of the liquids was not rate-controlling. The situation must be suitable for our ultimate aim in this study of understanding the mechanism of ESC in molecular terms. The growth rate under hydrostatic pressure up to  $2.25 \times 10^7$  N.m<sup>-2</sup> (220 atm) was also measured. The larger the amount of the activation enthalpy, the larger the size of the dilation activation volume. The nature of the molecular motion participating in the rate-determining process is discussed.

## 2. Experimental details

### 2.1. Materials

The polymer used was a low-density PE manufactured by Mitsubishi Petrochemical Co (MS-30). It

TABLE I Surfactants used as ESC active liquids

(a) Poly(oxyethylene)nonylphenyl ether  
C<sub>9</sub>H<sub>19</sub>C<sub>6</sub>H<sub>4</sub>O(CH<sub>2</sub>CH<sub>2</sub>O)<sub>*n*</sub>H

Commercial name	<i>n</i> <sup>†</sup>	HLB
Antarox Co630 <sup>‡</sup>	9.5	13.1
NS-208.5	8.5	12.6
NS-210	10.0	13.3
NS-212	12.0	14.1
NS-215	15.0	15.0
NS-220	20.0	16.0
NS-230	30.0	17.1

(b) Poly(oxyethylene)alkyl ether  
C<sub>*m*</sub>H<sub>2*m*+1</sub>O(CH<sub>2</sub>CH<sub>2</sub>O)<sub>*n*</sub>H

Commercial name	<i>m</i>	<i>n</i> <sup>†</sup>	HLB
P-213	16	13.0	14.1
S-220	18	20.0	15.3
K-230	12	30.0	17.5

<sup>†</sup>Averaged values.

<sup>‡</sup>Manufactured by Gaf Co.

Other surfactants were manufactured by Nippon Oil & Fats Co

is specified as: melt index at 190°C, 20 g/10 min; density at 25°C, 0.92 g ml<sup>-1</sup>; melting temperature, 112°C; and intrinsic viscosity in 75°C tetralin, 0.7 × 100 ml g<sup>-1</sup>.

The liquids used as ESC active liquids were *n*-propanol and aqueous solutions of two series of non-ionic surfactants, poly(oxyethylene)-nonylphenyl ethers and poly(oxyethylene)-alkyl ethers of various polymerization degrees. The surfactants were commercial ones and used without further purification. They are listed in Table I together with their commercial names by which they will be referred hereafter. The surfactants are graded by their hydrophile-lipophile balance (HLB), where the value of HLB is conveniently defined by a ratio HLB = 20 (molecular weight of oxyethylene group)/(molecular weight of surfactant molecule). Higher HLB surfactants are more hydrophile. The HLB values are included in Table I.

### 2.2. Specimen preparation

Polyethylene pellets were milled at 150°C for 15 min. The milled resin was cooled, sliced, and then pressed into thin plates at 150°C. They were remelted at 150°C for 15 min between two pieces of slide glass held at a fixed distance 0.6 mm to control surface roughness and thickness and then quenched into ice water. The plates were then annealed on the top of aqueous glycerin solution. If they were annealed on a flat base, they were sometimes damaged by their adherence to the base. After annealing. The plates were cooled at a rate of 10°C h<sup>-1</sup>. They were then cut by a razor into rectangles as shown in Fig. 1. The length *L* was 31.0 mm and thickness *D* was 0.55 ± 0.02 mm. The specimens were bent at 55°C and then set into a holder of width *B* = 14.0 ± 0.002 mm. At first, each specimen width, *W*, was changed in the range 14.3 to 15.2 mm to determine the effect of the amount of deformation but later it was fixed at 14.6 ± 0.05 mm. The experimental arrangement is shown in Fig. 1.

#### 2.2.1. Crack creation procedure

After the setting, each specimen was edge-notched along its ridge by a razor about 6 mm long as shown in Fig. 1. The front line of each notch was oblique to the specimen surface making an angle 40° with it (Fig. 2). The bent and notched specimens were than immersed in 20 g/100 ml Antarox (see Table I) aqueous solution at 30°C, which is a very active condition. After 30 min immersion, in

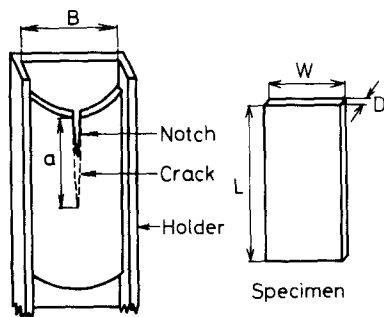

Figure 1 Experimental arrangement and a specimen.

each of about 70% of the specimens, a crack started at the tip of the notch. The uncracked specimens were discarded. After an additional 30 min immersion, the crack grew linearly along the ridge and reached a length of 8 to 10 mm. The specimens, kept in the holder, were washed by flowing water and transferred to the other surfactant solution in which the growth rate was to be measured. The crack continued to grow as a single, linear, and steady crack in the measuring conditions. For notches where the front line was normal to the specimen surface, more than 5 h were required to create cracks in the same proportion of specimens. It was better to create cracks by the proposed conditions than to create them in the rate-measuring conditions which were often not so active and required a long crack-creating period in which to form cracks. Cracks which experienced long creation periods often caused serious data scattering. The crack creation procedure described above is effective in shortening the period and forms an essential part of the experimental technique.

### 2.3. Growth-rate measurement

The crack length  $a$  or its increment  $\delta a$  was measured using a travelling microscope and then converted to the growth rate  $v$  by  $v = \delta a / \delta t$ , where  $\delta t$  is the time interval of successive measurements. The fronts of growing cracks were not linear but parabolla-shaped as shown in Fig. 2. Since the specimens were half transparent, each crack head, about 0.05 mm beneath the surface, was easily observed. Each measurement required a 4 min interruption of the immersion. The time interval  $\delta t$  does not include the interruption time.

The values of the growth rate were also investigated when the crack lengths were in the range 10 to 25 mm. In Fig. 3, three examples of the growth

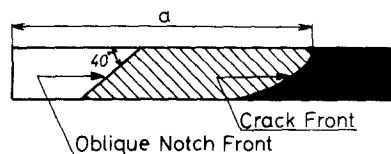

Figure 2 Cross-sectional view of a growing crack.

rate are plotted against crack length. A steady crack growth during the traverse over the specimens, except in the first and the final stages, is observed in the figure. It should also be noted that no appreciable fall in the growth rate by stress relaxation was observed after the longest experiment which continued for about 3000 min.

The values of the growth rate were determined by averaging over 8 to 16 specimens. When 2 g/100 ml AntaroX solution was used at 30°C, the ratio of the standard deviation to the mean value of the growth rate was about 10%. At lower temperatures, the ratio amounted to 20%.

Measurements were often made at several temperatures on a common crack. In this case, measurements were carried out in order of increasing temperature, as the annealing process applied to the specimens which are deformed by their ESC tests at a temperature higher than the test temperature, changes the specimens' ESC resistivity drastically, whereas annealing (or holding the deformed specimens for a while at a temperature) below the test temperature has little effect on the resistivity [2].

The growth rate of cracks being grown under superimposed hydrostatic pressure up to  $2.25 \times 10^7 \text{ N m}^{-2}$  was measured by the following procedure. After being treated by the crack

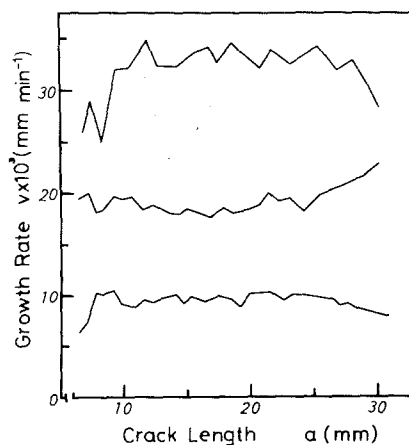

Figure 3 Variation of the values of ESC growth rate during their traverse over the specimens.

creation procedure, specimens set in a holder, together with an active liquid, were put into an autoclave held in a bath and pressurized by  $N_2$  gas. Each measurement required a 10 min interruption of the pressurizing and immersion. In the study of the pressure effect, the values of the growth rate were usually converted to ratios  $\alpha(P)/\alpha(P_0)$ , where  $\alpha(P)$  and  $\alpha(P_0)$  are, respectively, the rates obtained under hydrostatic pressure  $P$  and atmospheric pressure  $P_0$ . In that case,  $\alpha(P)$  and  $\alpha(P_0)$  of a common crack were measured by alternating pressure imposition.

#### 2.4. Other remarks

Preliminary experiments revealed that specimens with widths wider than 15.5 mm or with thicknesses thicker than 0.7 mm were inadequate. Cracks were found here and there on the surface of such a specimen. Mechanical interaction between cracks violates the stress field and renders the growth-rate measurement meaningless. No crack was developed in specimens with a width narrower than 14.3 mm.

The elementary theory of elasticity gives that the strain energy in a thin elastic plate bent in the manner shown in Fig. 1 is proportional to  $D^3(W-B)/B^2$  at far from the crack. The stress and strain near the tip of a crack with its front line normal to the surface, are proportional to  $d(W-B)^{1/2}/(Br^{1/2})$ , where  $d$  is the distance from the neutral plane and  $r$  is the radial distance from the crack front in the principal stress plane. The amount of deformation is conveniently expressed by a ratio  $(W-B)/B$  hereafter.

### 3. Results

ESC will start when the strain energy release rate for a crack is equal to or larger than the critical energy which is the necessary work done for the growth of the crack. The rate of growth of cracks is the main concern of this study. The growth rate of ESC is assumed to be determined by a molecular motion which is activated by thermal energy and is assisted by stress. As in the model of Eyring's flow theory, enough free volume is supposed to be associated with units performing that molecular motion. In that case, the formula giving the growth rate is reasonably assumed to be

$$v = v_0 \exp[\Delta S^*/R] \sinh[\sigma\Delta V^*/RT] \times \exp[-(\Delta E^* - \bar{\sigma}\Delta V^{**})/RT] \quad (1)$$

where  $\Delta S^*$  and  $\Delta E^*$  are the activation entropy

and the activation energy,  $\sigma$  and  $\bar{\sigma}$ , the relevant stress acting on the units and the mean of the principal stresses,  $\Delta V^*$  and  $\Delta V^{**}$ , the activation volume and the dilation activation volume, respectively. The front factor  $v_0$  is a slowly varying function of temperature. The term  $\sigma\Delta V^*$  is the work done by the stress in the course of the motion of the unit, and  $\bar{\sigma}\Delta V^{**}$  is the work done by the mean principle stress in the course of preparing the necessary amount of free volume. When the ratio  $\sigma\Delta V^*/RT \gg 1$ , the slopes of the Arrhenius plots of the growth rate give the activation enthalpy  $\Delta H^*$  ( $= \Delta E^* - \sigma\Delta V^* - \bar{\sigma}\Delta V^{**}$ ) and when  $\sigma\Delta V^*/RT \ll 1$ , they give  $\Delta E^* - \bar{\sigma}\Delta V^{**}$ . As will be discussed later, the ratios in the present experiments, seem to have intermediate values. The slopes of the Arrhenius plots, however, will be regarded as the activation enthalpy. The ambiguity introduced by this does not matter because the stress-dependent terms in the activation enthalpy  $\Delta H^*$  are estimated, to be fairly small, as will be also discussed later. The mean stress  $\bar{\sigma}$  may be written by

$$\bar{\sigma} = \bar{\sigma}_0 - P \quad (2)$$

where  $P$  is the superimposed hydrostatic pressure and  $\bar{\sigma}_0$  is the mean stress when  $P = 0$ .

In Fig. 4, the Arrhenius plots of the growth rate obtained under various amounts of deformation are shown. Specimens were annealed at  $80^\circ\text{C}$  for 1 h and 2 g/100 ml AntaroX solution was used as

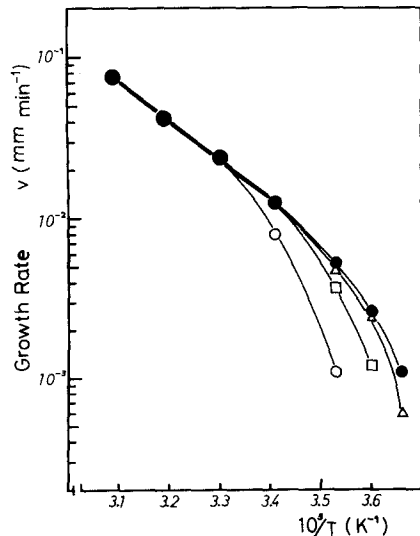

Figure 4 Arrhenius plots of growth rate of ESC in specimens under various amounts of deformation,  $(W-B)/B = 0.086$  ( $\bullet$ ),  $0.057$  ( $\Delta$ ),  $0.043$  ( $\square$ ), and  $0.021$  ( $\circ$ ). AntaroX 2 g/100 ml solution was used as an active liquid. Specimens were annealed at  $80^\circ\text{C}$  for 1 h.

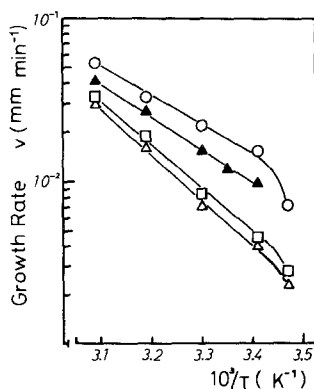

Figure 5 Arrhenius plots of growth rate of ESC in specimens annealed in different manners. Specimens were annealed at 100°C for 1 h (○), at 80°C for 24 h (▲), at 80°C for 1 h (△), and at 60°C for 1 h (□). AntaroX 0.2 g/100 ml solution was used as an active liquid.  $(W - B)/B = 0.043$ .

an active liquid. The points fall on a common line in the high-temperature range 25 to 60°C, irrespective of the amounts of deformation. At lower temperature, however, points are on separate curves and those obtained under less deformation fall more rapidly.

The values of the growth rate were changed by the crystalline texture of the PE specimens. Examples are shown in Fig. 5, where the data obtained from the specimens annealed in different manners are compared. Specimens annealed at a higher temperature or for a longer time exhibit a smaller value of activation enthalpy. The effect of annealing on the crystalline texture of low-density polyethylene is well known [12].

To simplify the situation, except in a few cases, the growth-rate measurements in the subsequent experiments were confined to the high-temperature range. All specimens were annealed at 80°C for 1 h. The amount of deformation,  $(W - B)/B$ , was fixed at 0.043 or  $W = 14.6 \pm 0.05$  mm.

The Arrhenius plots of the growth rate by NS-210 (see Table I) solutions at concentrations of 0.001 to 2 g/100 ml under atmospheric pressure are shown in Fig. 6. The values of the growth rate vary over a few hundredfold in the range studied. A remarkable fact is that the plots are nearly parallel which indicates an approximately constant value of activation enthalpy irrespective of surfactant concentration. It may be noteworthy that the lower limit of the concentration giving a parallel line, 0.001 g/100 ml, is well below the reported critical micelle concentration of NS-210, 0.005 g

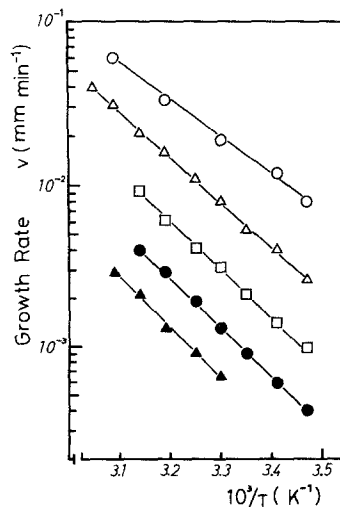

Figure 6 Arrhenius plots of growth rate of ESC by NS-210 solutions at concentrations of 2 g/100 ml (○), 0.2 g/100 ml (△), 0.02 g/100 ml (□), and 0.001 g/100 ml (●). Specimens were annealed at 80°C for 1 h.  $(W - B)/B = 0.043$ .

$\text{ml}^{-1}$  [13]. To obtain the points at that concentration, however, a special precaution was needed: the surfactant solution was frequently refreshed otherwise, growth gradually slowed down and finally stopped, suggesting non-availability of surfactant molecules. The points in the figure were obtained by repeated refreshment. The values of the growth rate at a given temperature increased monotonically with increase in surfactant concentration.

Growth-rate measurements under atmospheric pressure were repeated using the surfactants in Table I. The values of the activation enthalpy changed with change of surfactants but were approximately constant irrespective of the concen-

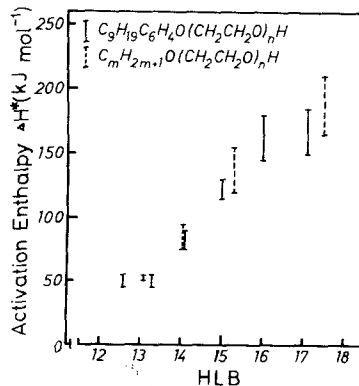

Figure 7 The activation enthalpy  $\Delta H^*$  versus HLB of two series of surfactants, poly(oxyethylene)-nonylphenyl ethers and poly(oxyethylene)-alkyl ethers.

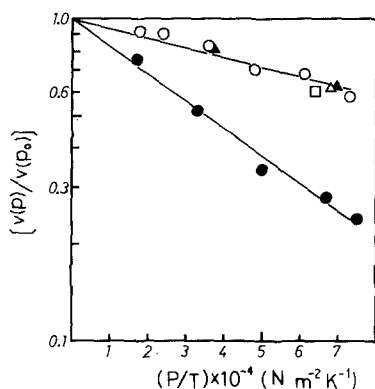

Figure 8 Logarithms of ESC growth rate ratio  $v(P)/v(P_0)$  versus  $P/T$ . Growth rate was measured at 20° C (●), 30° C (○), 35° C (◻), 45° C (▲), and 50° C (△) by NS-215 2 g/100 ml solution. Specimens were annealed at 80° C for 1 h.  $(W - B)/B = 0.043$ .

tration, as in ESC by NS-210 solutions (Table II). The values are plotted in Fig. 7 as a function of HLB. The points from the two surfactant series fall on a common curve indicating the possibility of defining the ESC activity of a liquid by its molecular parameter. In every surfactant studied, the growth rate increased with increase in concentration.

Liquid-liquid phase separation was found in NS-210 and more lipophile surfactants at high temperatures and high concentrations. The data obtained in the two-phase region were discarded.

The logarithms of the ratios of the growth rate by NS-215 solutions under hydrostatic pressure  $P$  to those under atmospheric pressure  $P_0$  are plotted

against  $P/T$  in Fig. 8. The sizes of the dilation activation volume are obtained from the slopes of the lines. The points obtained in the high-temperature range fall on a common line, indicating a constant dilation activation volume. At lower temperatures, the points fall on another line. The results are given in Table II.

## 4. Discussion

Unless otherwise stated, the following discussion mainly concerns ESC in the high-temperature range.

### 4.1. Crude estimation of the activation parameters related to stresses

At the tips of cracks, owing to the stress concentrations, the PE texture must be yielded. To estimate the stresses at the tip of a crack in a bent plate with finite thickness, by the elastic-plastic theory, is a difficult problem. However, it will be allowable for us to assume that the stress  $\sigma$  and the mean stress  $\bar{\sigma}_0$  are in the order of the PE yielding stress. The tensile yielding stress of the PE, MS-30, was 8.5 MNm<sup>-2</sup> at 30° C.<sup>†</sup> We have no data for the activation volume  $\Delta V^*$  at present. By experiments on large strain deformation of a high-density PE, Davis and Pampillo, and Wu and Turner found that the sizes of the activation volume are around ten times those of the dilation activation volume [14, 15]. Following their results, let us put  $\Delta V^* = 10 \Delta V^{**}$ . By using the numerical data in Table II and putting  $\sigma = \bar{\sigma}_0 = 10 \text{ MN m}^{-2}$ , the range of the values of the ratio  $\sigma \Delta V^*/RT$  is estimated to be 1 to 5. The ratio,  $\Delta E^* : \sigma \Delta V^* : \bar{\sigma}_0 \Delta V^{**}$ , in any liquid

TABLE II Activation enthalpy  $\Delta H^*$  and dilation activation volume  $\Delta V^{**}$  of ESC growth rate in the temperature range 25 to 60° C. PE used was MS-30. Specimens were annealed at 80° C for 1 h

Surfactant	Concentration range (g/100 ml)	$\Delta H^*$ (kJ mol <sup>-1</sup> )	$\Delta V^{**}$ (ml mol <sup>-1</sup> )
Antarox Co630	0.002–20.0	50–55 <sup>†</sup>	27–30 <sup>†</sup>
NS-208.5	0.002–0.2	45–55	
NS-210	0.001–2.0	45–55	27–33
NS-212	2.0	75–90	
NS-215	0.02–2.0	115–130	50–60
NS-220	2.0–10.0	145–180	
NS-230	2.0–10.0	150–185	
P-213	0.2–20.0	75–95	35–40
S-220	0.2–20.0	120–155	
K-230	2.0–20.0	165–210	
<i>n</i> -propanol	50, 100	225–275	110–145

<sup>†</sup>The data are shown by intervals including estimated errors.

<sup>†</sup>The quoted yield stress was obtained by the specification of JIS 6760 with cross-head speed 500 mm min<sup>-1</sup>. The strain rates at crack tips are unknown but probably in the interval of a few decades below the strain rate of the tensile test.

studied, is roughly 100 : 10 : 1 when no hydrostatic pressure is imposed.

Contributions to the activation enthalpy from the stresses are decreased by elevation of temperature and by stress relaxation. The tensile yielding stress was  $4.8 \text{ MN m}^{-2}$  at  $50^\circ \text{C}$ . The time relevant to the stress relaxation at a crack tip is, reasonably, the characteristic time  $\tau$  defined by  $1/\tau = (v/\Delta) + (1/t)$ , where  $\Delta$  is the length of the yield zone ahead of the crack tip and  $t$  is the time from loading [3]. The stress at the crack tip depends on  $\tau$  in such a manner that  $\sigma(\tau) = \sigma_0 \tau^{-m}$ . The characteristic time in an appropriate unit was in the range 1 to  $10^3$  in ESC by AntaroX solutions at various concentrations. If we put  $m = 0.1$ , as in high-density PE [3], the equation gives  $\sigma(10^3) = 0.5 \sigma(1)$ . Temperature elevation and stress relaxation thus reduce the stress contributions by a factor  $\frac{1}{2}$  to  $\frac{1}{4}$ . If work-hardening is not negligible, the stress contributions are influenced by the amount of deformation.

The stress contributions to the activation enthalpy are indeed small but influenced by temperature, stress relaxation, and amount of deformation. The data scattering masks the influences, and the circumstances give the linear Arrhenius plots in the high-temperature range. The values of the ratio  $\sigma \Delta V^*/RT$  suggest that the rate of the motion of the units in the direction to close a crack is not negligible.

A larger size dilation activation volume was found at a lower temperature (Fig. 8). The tensile yield stress was  $15 \text{ MN m}^{-2}$  at  $0^\circ \text{C}$ . At lower temperatures, the stress contributions are thus considerable.

#### 4.2. The rate determining molecular motion

Many kinds of molecular motion must be involved in the growth of a crack. One of them may be that involved in the yielding of a crystal in the periphery of a crack tip or the diffusion of surfactant molecules onto the crack tip, etc. The rate determining molecular motion should be assumed among them. Values of the activation enthalpy depend on the kind of surfactant and the crystalline texture of PE. Both the surfactants and PE are responsible for the activation process. It is natural, therefore, to assume that the rate determining molecular motion is performed by motional units of PE molecules, or Pe segments, in the regions where PE molecules and surfactant molecules are in contact.

The values of the dilation activation volume were in the range 30 to  $120 \text{ ml mol}^{-1}$ . The values are only several times the volume of the PE monomer unit,  $\text{C}_2\text{H}_4$ , and much smaller than the acceptable volume of the motional unit of PE molecules. Because, some free volume is to be allotted to the motional units, the value of the dilation activation volume is not the volume of the motional unit but a measure of an additional volume needed for the motion to take place [16]. In our experiments, the sizes of the dilation activation volume decrease with decrease in the amount of the activation enthalpy (Fig. 9). In other words, more free volume is introduced into the contact regions by surfactant molecules giving a lower activation enthalpy or by more active surfactant molecules. The phenomenon is like molecular motion in a mixture of a polymer and a diluent where polymer segment mobility is increased by the free volume introduced by the diluent. It seems that PE molecules and surfactant molecules are in a mixed state in some localized regions on the PE surface at a crack tip.

That the values of the activation enthalpy are nearly constant irrespective of surfactant concentration suggests that there is no appreciable change in the state of mixing, such as the mixing ratio in the proposed localized regions. In due course, the activation entropy,  $\Delta S^*$ , is expected to be constant over the same range. In view of the bulkiness and incompatibility of their hydrophile parts with PE, permeation of surfactant molecules deep in PE is not conceivable without the extraordinary enhancing effect of stress. The depth of permeation

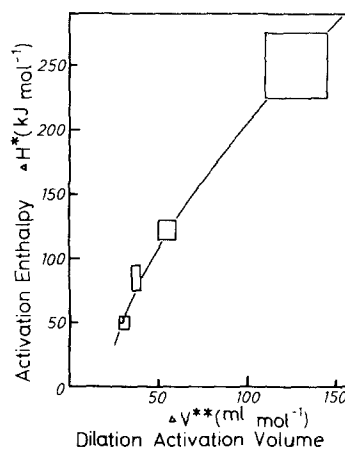

Figure 9 The correlation between the values of the activation enthalpy and those of the dilation activation volume.

may be related to the "brittle likeness" of ESC. At present we have no quantitative estimate of the depth; it will be given after quantitative elucidation of the stress effect. On the other hand, it is natural to assume that the areal extent of the regions covering PE at a crack tip increases with increase in the concentrations.

Increase in the growth rate with increase in the surfactant concentrations at a given temperature is due to the increase in  $v_0$ , the front factor in Equation 1. The factor is proportional to the number of motional units potentially activatable and is inversely proportional to the number of motions necessary for a unit distance growth of a crack. It may be plausible to suppose that the former is proportional to the extent of the proposed localized mixing regions. In ESC by NS-210 solutions, we found a relation  $v_0 \propto C^{1/3}$ , where  $C$  is the concentration. The relation is not yet established for other surfactants.

The authors present view is that the increased mobility of PE molecules in localized regions is essential to the activation process in ESC of PE. The idea may be supported by Brown's work referred to in Section 1. However, it does not necessarily rule out the concept of the surface tension effect reducing the critical energy.

The distribution of alcohol molecules in PE will be different from those of surfactants because of their expected large permeability [17]. This might modify the mechanism of ESC by propanol as suggested by the large values of  $\Delta H^*$  and  $\Delta V^{**}$  exhibited by it.

Only one grade of PE was used in this work. The effect of molecular weight on the proposed activation process is very interesting and must be studied. Further study, including the molecular weight effect, is now in progress to check the proposed mechanism and to obtain a detailed picture.

## Acknowledgement

The authors are grateful to Mitsubishi Petrochemical Co and Nippon Oil & Fats Co for their presentation of materials. It should also be acknowledged that the data of PE yielding stress were from Mitsubishi Petrochemical Co. The authors thank Mr M. Sugiyama for his discussion during the work. Part of the study was supported by a Grant-in-Aid for Scientific Research presented by the Japanese Ministry of Education, Science and Culture in 1977.

## References

1. J. B. HOWARD, in "Crystalline Olefine Polymers", Part II, edited by R. A. V. Raff and K. W. Doak (Interscience, New York, 1964).
2. H. OKAMOTO, *Kohbunshi Kagaku* **28** (1971) 97.
3. J. G. WILLIAMS and G. P. MARSHALL, *Proc. Roy. Soc. A* **342** (1975) 55.
4. T. SAITO, *Polymer J.* **11** (1979) 201.
5. R. P. KAMBOUR, *J. Polymer Sci. Macromol. Rev.* **7** (1973) 1.
6. E. H. ANDREWS and L. BEVAN, *Polymer* **13** (1972) 337.
7. P. HITMAIR and R. ULLMAN, *J. Appl. Polymer Sci.* **6** (1962) 1.
8. H. R. BROWN, *Polymer* **19** (1978) 1186.
9. A. N. GENT, *J. Mater. Sci.* **5** (1970) 925.
10. R. N. HAWARD and D. R. J. OWEN, *Proc. Roy. Soc. A* **352** (1977) 505.
11. Y. OHDE and H. OKAMOTO, *Rep. Prog. Polymer Phys. Japan* **21** (1978) 265.
12. H. OKAMOTO, *J. Polymer Sci. A-2* **8** (1970) 311.
13. M. S. SCHIK, S. M. ATLAS and F. R. EIRICH, *J. Phys. Chem.* **66** (1962) 1326.
14. L. A. DAVIS and C. A. PAMPILLO, *J. Appl. Phys.* **43** (1972) 4277.
15. W. WU and A. P. L. TUNER, *J. Polymer Sci. Polymer Phys. Ed.* **13** (1975) 19.
16. R. A. ASSINK, *ibid.* **15** (1977) 227.
17. P. L. SONI and P. H. GEIL, *J. Appl. Polymer Sci.* **23** (1979) 1167.

Received 14 August and accepted 13 November 1979.